

HAYWARD™ PHANTOM

TURBO™

Attention Installer:

This manual contains important information about the installation, operation and safe use of this automatic pool cleaner.

This Owner's Guide should be given to the owner / operator of this cleaner to keep.

Atención instaladores:

Este manual contiene información importante sobre la instalación, el funcionamiento y el uso seguro de la limpiadora automática de piscinas.

El dueño/operador de esta limpiadora debe recibir y conservar la Guía del usuario.



Owner's Guide Model 6000

- Important Safety Instructions
- Installation Instructions
- Parts List
- Warranty Registration Card
- Warranty

Guía del usuario Modelo 6000

- Instrucciones importantes de seguridad
- Instrucciones para la instalación
- Nómina de piezas
- Tarjeta de registro de garantía
- Garantía

Important Safety Instructions

Warning

Read this entire Owner's Guide before assembling and installing the Phantom cleaner. Failure to follow safety warnings and Owner's Guide instructions can result in severe injury, death or property damage.

For additional free copies of the Owner's Guide you can download them from www.haywardnet.com or call (800) 227-1477.

Warning - Risk of Electrical Shock

The Hayward Phantom Turbo Automatic Pool Cleaner is designed to connect to a threaded 1-1/2 inch female pipe fitting on a dedicated return line that is powered by a 3/4 H.P. Booster Pump. You should have a licensed electrician install the cleaner's booster pump. **The Booster Pump must be installed in accordance with the National Electrical Code and all local code requirements. Failure to do so can result in serious injury or death.**

Warning - Risk of Injury

Failure to follow the safety warnings below may result in severe injury, death or property damage.

- Always disconnect and remove the cleaner and pressure hose before entering the pool.
- Disconnect the Safety Rope that separates the pool's shallow end from the pool's deep end, before running the Phantom. Always reconnect the Safety Rope before entering the pool.
- Always handle with care. Do not let children or pets play with the cleaner; it is not a toy.
- Always turn the Booster Pump **OFF** before handling the cleaner.
- Do not operate outside the pool. The Phantom Turbo Cleaner and hoses contain high-pressure water jets that may cause injury.
- Disconnect pressure hose from the universal wall fitting before removing the cleaner from the pool.
- **Never** point any of the cleaner's high-pressure jets, pressure hose, pressure gauge or sweep hose at any person or pet.

Important Information

Caution - Risk of Equipment Damage

- Always turn the Filtration Pump on **before** turning the booster pump on. Running the booster pump dry will damage the booster pump and is not covered by the Hayward warranty.

- Always disconnect and remove the Phantom cleaner and hoses from the pool before cleaning or backwashing the pool filter.
- After cleaning or backwashing the pool filter, allow the filtration system to run for a minimum of five minutes or until all debris has been flushed from plumbing lines before reconnecting the Phantom cleaner.
- New plumbing lines must be flushed out before connecting the Phantom cleaner.
- The Phantom cleaner should not be used to remove plaster dust or construction debris from new or renovated pools.
- The Phantom cleaner should not be used to remove excessive sand (dense debris) following wind or sandstorms.
- Always disconnect and remove the Phantom cleaner and hoses before chemically shocking the pool.
- Only operate the Phantom cleaner for the period of time necessary to clean the pool. Excessive use is unnecessary and will cause cleaner parts to prematurely wear.
- Regularly inspect the cleaner and hoses; do not use if damaged or if any rough edges are visible on the cleaner; this can cause damage to the pool.
- Lift the Phantom cleaner by its wing (Part A, page 4), never by the hose or bag.

Disclaimer

- Pool plaster is affected by age, water chemistry, etc.
- Pool plaster can deteriorate over time.
- The integrity of "good" pool plaster is such that a pool vacuum cleaner – automatic or manual – cannot remove the plaster.
- The integrity of "good" pool plaster is such that the plaster will cause wear on the cleaner, the cleaner will not wear out "good" pool plaster.
- Vinyl pool liners are affected by age, sunlight, and water chemistry.
- Vinyl pool liners can become brittle and weak.
- Vinyl pool liners can be affected by the installation and the pool's surroundings.
- Patterns on vinyl pool liners vary in quality.
- When installing the Phantom cleaner, you assume responsibility for the condition of the pool's surroundings and chemistry.

Contents

Important Safety Instructions	1
Disclaimer	1
Introduction	3
For Your Records	3
Principle Parts	4
Preparing the Pool	5
Dedicated Return Line	5
Tools Needed for Installation	5
Connecting Phantom Turbo Cleaner to Pool	6
Installing the Universal Wall Fitting	6
Assembling and Sizing the Rigid Pressure Hose	7
Connecting the Rigid Pressure Hose	8
Disconnecting a Hose Pipe	8
Connecting Hose to Wall	8
Operating the Phantom Turbo Cleaner	9
Setting Pressure	9
Large Capacity Debris Bag	10
Attaching Debris Bag	10
Removing Debris Bag	10
Emptying Debris Bag	10
Sand (Dense Debris)	10
Correctly Operating Phantom Turbo Cleaner	11
Movement	11
Spin-Out	11
Sweep Hose	11
Cleaning	11
Fine Debris	11
Sand (Dense Debris)	11
Pressure Hose	11
Phantom Turbo Cleaner Adjustments	12
Changing Spin-Out Frequency	12
Changing Spin-Out Cam	12
Adjusting Spin-Out Duration	12
Changing Top and Bottom Operation	13
Adjusting Sweep Hose Power	13
Maintenance	14
Removing Phantom Turbo Cleaner from Pool	14
Emptying Debris Bag	14
Cleaning the In-Line Filter	14
Sweep Hose	15
Storing the Phantom Turbo Cleaner	15
Winterizing	15
Periodic Freezing Conditions	15
Troubleshooting	16
Booster Pump	17
Phantom Turbo Parts Diagram and Replacement Parts List	18
Limited Warranty	19

Congratulations on your purchase of the Hayward Phantom Turbo Automatic Pool Cleaner. The Hayward Phantom Turbo is the only Total Pool Cleaner. The Phantom Turbo is designed to not only to clean your pool's bottom and sides, but also to skim the water's surface as well – all automatically!

This revolutionary design offers the following features:

- **Faster Cleaning**
 - Wider Vacuum Nozzle
 - Powerful Sweep Hose
- **Large Debris Pick-up**
 - Large Suction Inlet
 - Three High Pressure Water Jets
- **Less Frequent Bag Cleaning**
 - Large Capacity Bag
 - Easy to remove, clean and replace debris bag
- **Complete Pool Coverage**
 - Patented AquaDrive™ water jet propulsion
 - Randomized Cleaning & Spin-out
 - Sweeps debris off steps while skimming
- **Cleans the Pool Bottom, Sides and Skims the Water's Surface**
 - Automatic Ascent and Descent
 - Switch for Bottom & Side Cleaning Only or Surface Skimming Only
- **Less Wear on Pool Surface**
 - Patented AquaDrive water jet propulsion: no powered wheels wearing pool surfaces
- **Easy Installation**

A limited warranty program protects your Hayward Phantom Turbo cleaner. To take full advantage of this limited warranty, please read, complete and **return the Limited Warranty Registration Card within 14 days of purchase date or go to www.haywardnet.com/warranty to complete online.** Your warranty card is included in this Owner's Guide.

Important

This Owner's Guide is for Phantom Turbo owners who want to install their Automatic Pool Cleaner. However, we recommend that an Authorized Hayward Dealer install the cleaner.

The Hayward 6060 Booster Pump purchased separately or as part of the Phantom Turbo Automatic Pool Cleaner package offers optimum cleaner performance. Use of other booster pumps will provide acceptable performance if they deliver at least 35 Pounds per Square Inch (PSI) at 12 Gallons Per Minute (GPM) at the dedicated line pool wall fitting. For electrical and plumbing installation procedures for the Hayward Booster Pump, refer to the Owner's Guide that comes with the Hayward 6060 Booster Pump.

For Your Records

Purchase Date

Serial Number

(located on back of cleaner)

Number of Rigid Pipe Assemblies Used

Pressure Gauge Reading

Principle Parts

⚠ Caution - Risk of Equipment Damage

Hose may be stored folded pipe-to-pipe. Only first 3-foot hose section and sweep hose must be stored straight, **not coiled**.

- A. Wing
- B. Large Capacity Debris Bag with Float Closure
- C. Cleaner Connector
- D. Sweep Hose Connector
- E. Sweep Hose Adjustment Knob
- F. Cam Cap
- G. Rigid Pressure Hose
- H. Hose Float
- I. Hose Pipe Coupling
- J. Hose Swivel - (See special installation instructions in this manual)
- K. Adjustable Wall Quick Connect
- L. Sweep Hose
- M. Wear Roller
- N. Rigid Hose Pipe
- O. Universal Wall Fitting
- P. Top / Auto / Bottom Switch
- Q. In-Line Filter
- R. Hose Swivel Assembly
- S. Hose Cleaner End Assembly
- T. Hose Wall End Assembly
- U. Setup Pressure Gauge

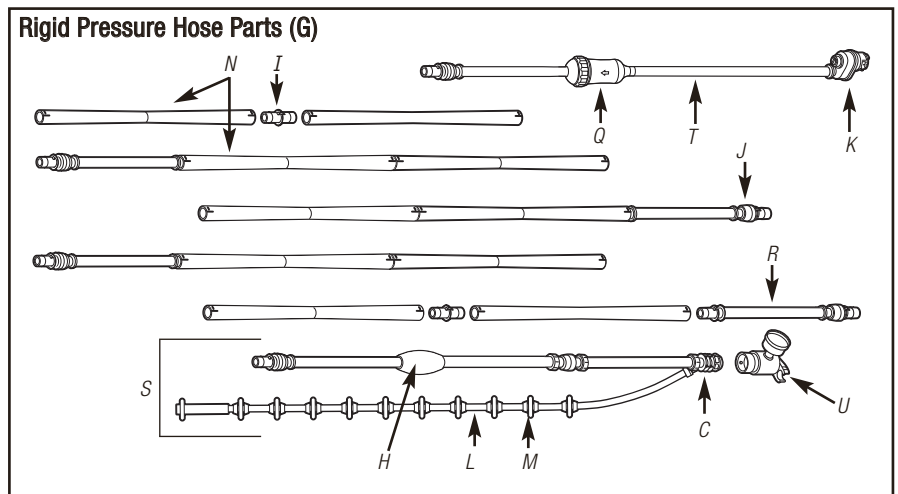
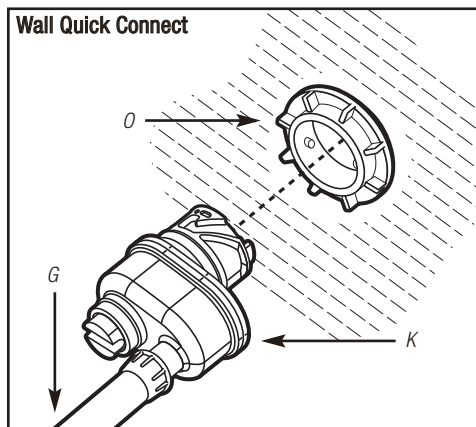
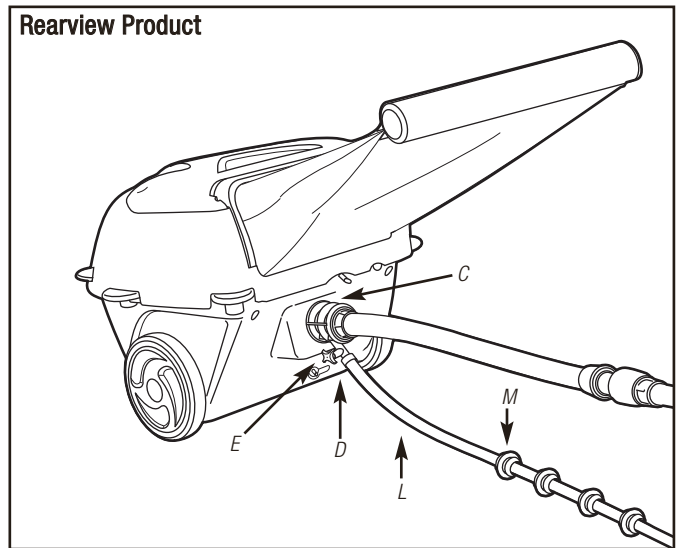
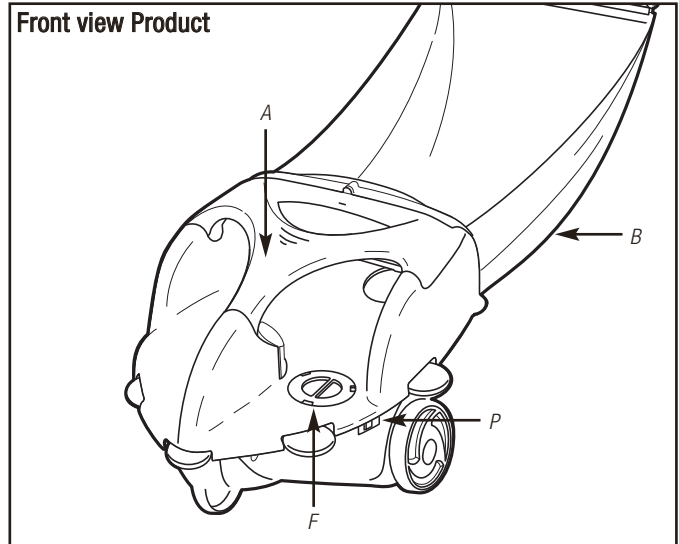

The Phantom Turbo cleaner should not be used to clean the pool for spring start-up until the following steps have been taken:

1. Clear the pool of any objects that might interfere with the cleaner's operation.
2. Check to see that the water is at the recommended level.
3. Check the water chemistry. The water should be properly balanced (ph level) and the pool free from algae.

Note: Algae can adversely affect the operation and performance of the cleaner.

4. Clean or backwash the filtration system without the Phantom cleaner in the pool.

Caution - Risk of Equipment Damage.

Always disconnect the Phantom Turbo Cleaner and hoses from the Universal Wall Fitting and remove from pool before backwashing or cleaning the filtration system. Failure to do so can damage the Booster Pump and Cleaner.

5. Clean the filtration system pump's strainer basket

Note: After installing the Phantom Turbo cleaner, clean the filtration system at regular intervals according to individual pool conditions.

New Pool Construction

1. Brush newly constructed pool surface and manually vacuum new surface debris *before* installing the Phantom.

Sand (dense debris)

Always empty the Phantom bag when sand (or heavy debris) effects the cleaner's stability

Pools with excessive amounts of sand should be manually vacuumed before installing the Phantom.

Dedicated Booster Pump Return Line

The cleaner is designed to connect to a 1-1/2 inch dedicated return line that is at least 6 inches below the normal water level with 1-1/2 inch female threads. If the dedicated return line has 3/4 inch female threads, you will need to purchase a 1-1/2 inch NPTF x 3/4 inch NPTM adapter.

Tools Needed for Installation

- Flat blade screwdriver for adjusting the Regulator on the Wall Quick Connect.
- Rigid Pressure Hose Measuring Tape (included in Bag #1).

Connecting the Phantom Turbo Cleaner To Pool

Installing Universal Wall Fitting

Builders: Install the Dedicated Return Line at the midpoint of the pool's long wall.

Specification: Dedicated Return Line in Pool Wall.

Depth: At least 6 inches below water level.

Size: 1-1/2 inch NPT Female Threaded.

1. Flush plumbing lines before proceeding.
2. Turn Booster Pump and Main Filtration Pump **OFF**.
3. Remove plug or existing Universal Wall Fitting from previously installed pool cleaner (if any).
4. Remove the Universal Wall Fitting (part O) and Teflon® tape from Bag #1.
5. When installing or re-installing the Universal Wall Fitting use Teflon® tape on its plastic threads. Leave two starting threads on the end of the Universal Wall Fitting un-taped.
6. Screw the Universal Wall Fitting into the Dedicated Return Line.

Important: Turn the Universal Wall Fitting 1 full turn to the right to engage starting threads. Be sure both parts are started properly (not cross threaded) then resume tightening – hand tighten only. **The Universal Wall Fitting may not screw all the way into the Dedicated Return Line. Do not over tighten.**

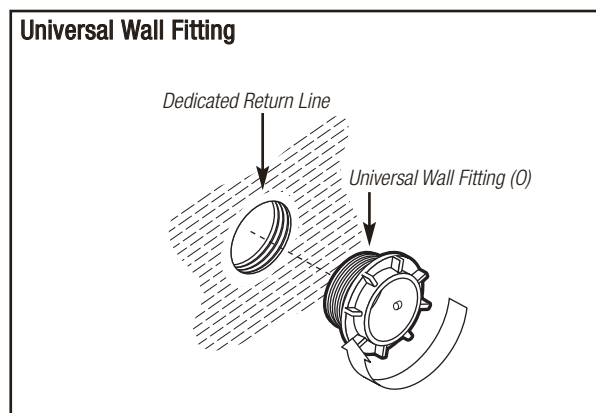

Teflon® is a registered trademark of E.I. du Pont de Nemours and Company.

Assembling and Sizing the Rigid Pressure Hose

Assembling and Sizing the Rigid Pressure Hose

1. Open the plastic bag labeled #1 that contains 10 Rigid Hose Pipes (Part N) and 5 Hose Pipe Couplings (Part I).
2. Lubricate the 5 Hose Pipe Couplings by dunking them in soapy water.
3. Align the Barbs on the Hose Pipe Coupling with the Tabs on the Rigid Hose Pipes and snap together. Be sure the black o-ring does not slip out of the groove on the Hose Pipe Coupling (if the o-ring is visible through the latch opening when pipes are snapped together the o-ring has slipped out of the groove and will leak)

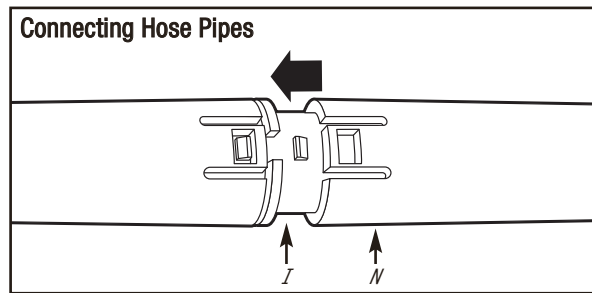

4. Make 5 **Sets of Pipe Assemblies** by connecting 1 Rigid Hose Pipe onto each end of the Hose Pipe Couplings.

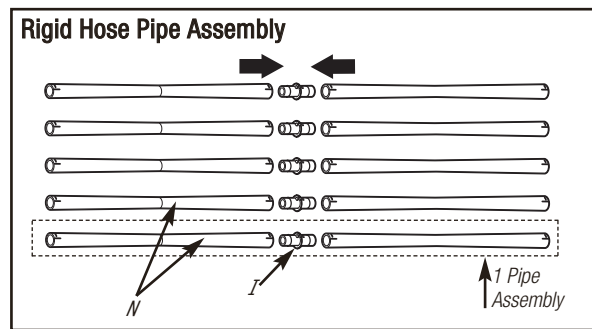

5. Locate the "Measuring Tape" (packed in Bag #1), secure the end of the tape marked "Wall Connector End" on the pool coping immediately above the Universal Wall Fitting.
6. Unroll the Measuring Tape, walk around the pool to the farthest point along the pool wall from the Universal Wall Fitting.

At the farthest point from the Universal Wall Fitting hold the Measuring Tape at the pool edge/coping and read the number of Pipe Assemblies specified on the tape.

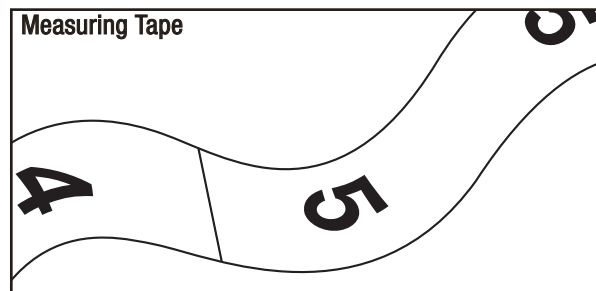
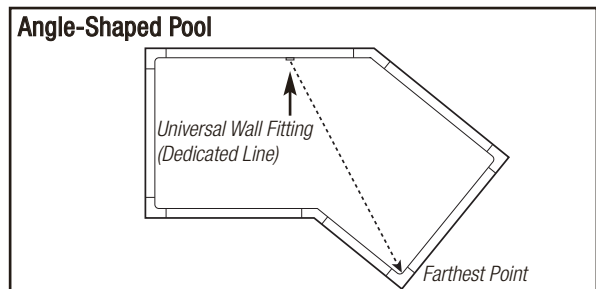
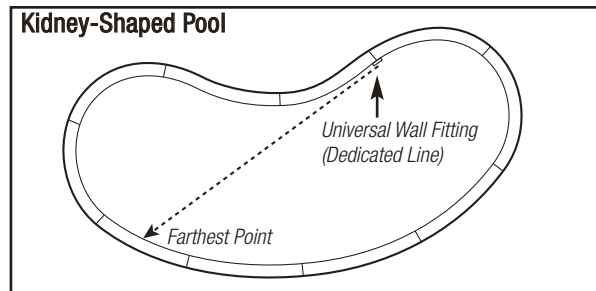
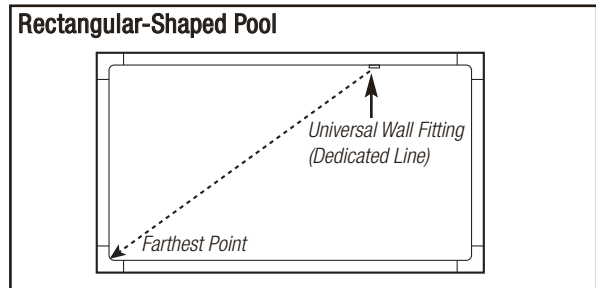

- a. **Note:** If the measuring tape specifies more than 5 Pipe Assemblies, you need to purchase the additional Pipe sections (P/N AX6000HE) from your Authorized Hayward Dealer.
- b. If the measuring tape specifies fewer than 5 Pipe Assemblies, set the remaining Pipe Assemblies aside these will not be needed.

Connecting The Rigid Pressure Hose to Pool

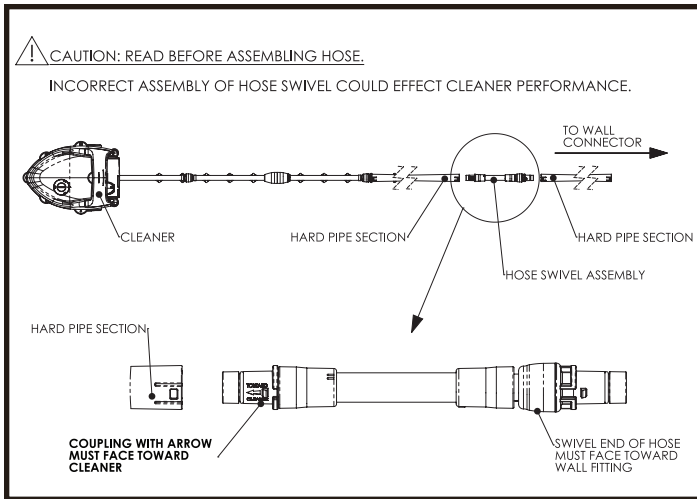

- Lubricate the swivel on the 3 ft. Hose Wall End Assembly (Part T) in soapy water then snap into one of the Pipe Assemblies.

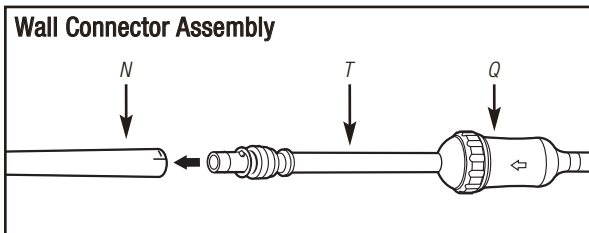

- Lubricate the swivel on the Hose Cleaner End Assembly (Part S) in soapy water then snap into a different Pipe Assembly.

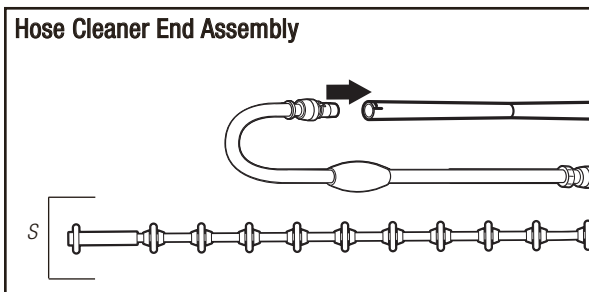

- Open Bag #2 and lubricate both ends of the Hose Swivel Assemblies (Part R) in soapy water. Connect the Pipe Assemblies by snapping the Hose Swivel Assemblies into each of the Pipe Assemblies.

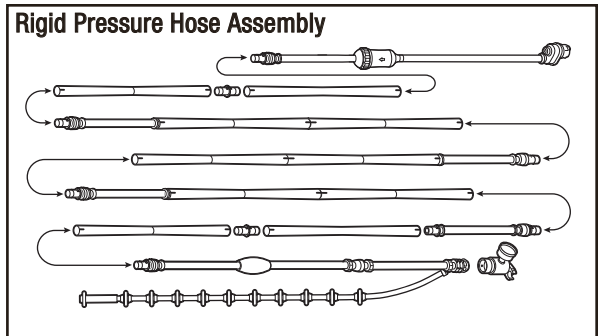
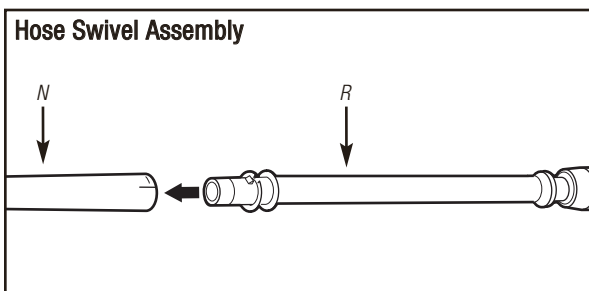

Disconnecting a Hose Pipe

If it is necessary to shorten, lengthen or replace a component of the Rigid Pressure Hose, the Snap Fits can be undone with two small screwdrivers.

Connecting Hose to Wall Fitting

- With the Booster Pump and Filtration system turned **OFF**, look down from the pool deck and hold the Wall Quick Connect so the hose is to the left and the adjustment knob is to the right. Insert the Wall Quick Connect into the Universal Wall Fitting and turn it to the left (counter clockwise) to lock. The hose should be on the bottom below the adjustment knob.
- Pull the Wall Quick Connect outward to check that the Wall Quick Connect is locked into the Universal Wall Fitting.
- To **disconnect** the hose, first turn the Booster Pump and Filtration pump **OFF** then push the Wall Quick Connect toward the wall, turn it to the right (clockwise) and pull the Wall Quick Connect out of the Universal Wall Fitting.

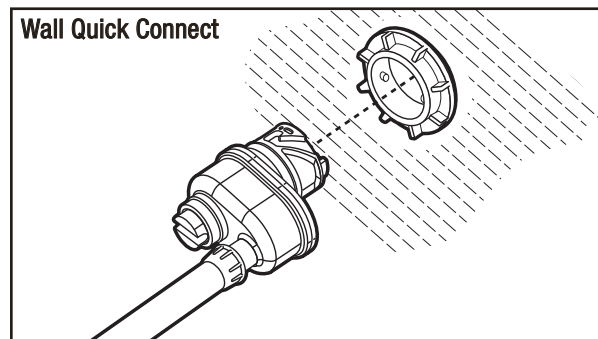

It is essential that the Hose Swivel Assemblies are installed correctly to ensure tangle free operation of the Phantom Turbo.

Operating the Phantom Turbo Cleaner

⚠ Warning - Risk of Injury

The Filtration and Booster Pumps must be **OFF** when connecting or disconnecting cleaner hose.

⚠ Caution - Risk of Equipment Damage

The filter pump must always be run to clear air from the system before turning the Booster Pump **ON**. **Never run** the Booster Pump without the main filter pump **ON**. Running the Booster Pump dry will damage the Booster Pump and void the warranty.

Operating the Phantom Turbo Cleaner

1. Be sure all filtration system valves are open and supplying water to the Booster Pump.
2. Be sure valves to and from the Booster Pump and dedicated return line are fully opened.
3. The Phantom Turbo Cleaner and its Booster Pump can only operate when the pool's filter pump is operating.

⚠ Caution - Risk of Equipment Damage

Failure to open valves fully and/or failure to have the filtration system operating will damage the Booster Pump. This damage voids the Booster Pump's warranty.

Setting Pressure

Important: The cleaner will not operate properly if the pressure is not properly set. Too little pressure will prevent proper movement and cleaning. Too much pressure will cause poor cleaning and premature wear of Cleaner parts.

⚠ Warning - Risk of Injury

Be careful to hold the Cleaner Connector (Part C) with the Setup Pressure Gauge (Part U) attached under water and not to be sprayed by the hole in the Setup Pressure Gauge or by the Sweep Hose. **Never** point a jet or hose at people or pets.

Clip the Setup Pressure Gauge to the hose near the Wall Quick Connect.

1. Turn the filtration system pump **ON** then the Booster Pump **ON**. Read the pressure on the Setup Pressure Gauge connected to the Cleaner Connector. Use a flat blade screwdriver to adjust the Wall Quick Connect Knob (see figure 2) until the pressure reads 25 PSI (+/- 5 PSI).
Note: The Wall Quick Connect can be adjusted from "0" (fully closed) to "5" (fully open). Do **NOT** force the adjustment knob beyond "0" or "5".
2. If the Wall Connector is on Position "5" (fully open) and the

pressure is still below 20 PSI, check for clogged Filter, Pump Strainer Basket, Main Drain, Skimmer Basket, etc., to determine why there is insufficient water pressure at the dedicated line. If more pressure is still required have an Authorized Hayward Pool Dealer or Service person check the Booster Pump, Filtration System and Plumbing to determine if they are functioning correctly.

3. Turn the Booster Pump and Filtration Pump **OFF**.
4. **Remove the Setup Pressure Gauge** from the Cleaner Connector. Store the Setup Pressure Gauge with the Owner's Guide in a safe place.
5. Attach the Cleaner Connector to Cleaner. The Sweep Hose should be directly below the Pressure Hose.
6. Place the cleaner in the pool, turn the Filtration system **ON**, then turn the Booster Pump **ON**.

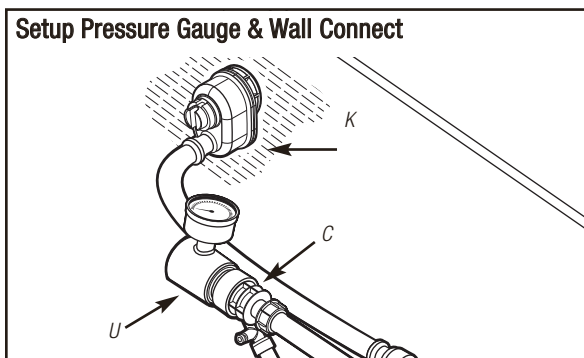

Figure 1

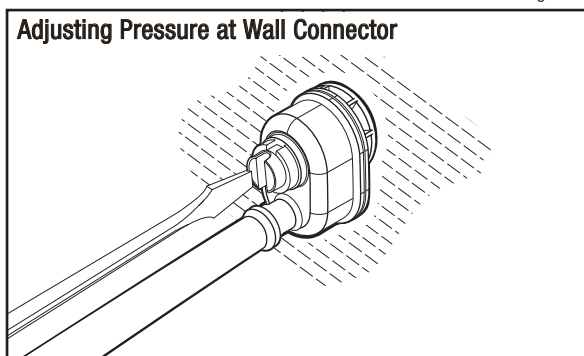

Figure 2

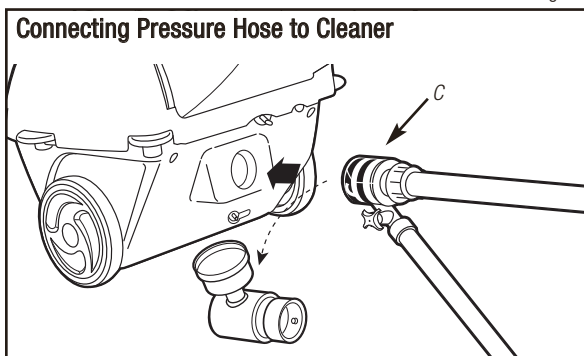

Figure 3

Large Capacity Debris Bag

Attaching Debris Bag (see figure 1)

1. Place the frame of the Debris Bag against the back of the Cleaner as shown.
2. Press down on the top corners of the frame.
3. Press down on the top-center of the frame to lock the Debris Bag in place.

Removing Debris Bag (see figure 2)

1. Pull the top of the Debris Bag frame back (1) and then up (2).

Note: If you allow the bag to dry, the debris will be easier to remove.

Emptying Debris Bag (see figure 3)

1. Hold Bag over trash can or wherever debris is to be placed.
2. Slide Float Closure off of bag.
3. Hold open edges apart and shake debris from bag.
4. Slide Float Closure onto bag.

Sand (dense debris)

If too much sand or heavy debris is collected in the Debris Bag, the bag will “droop” over the hose while on the bottom and the Cleaner may not be able to ascend to the surface properly. If you observe the bag drooping over the hose turn the booster pump off and empty the Debris Bag.

Note: Pools with excessive amounts of sand should be manually vacuumed before installing the Phantom Turbo.

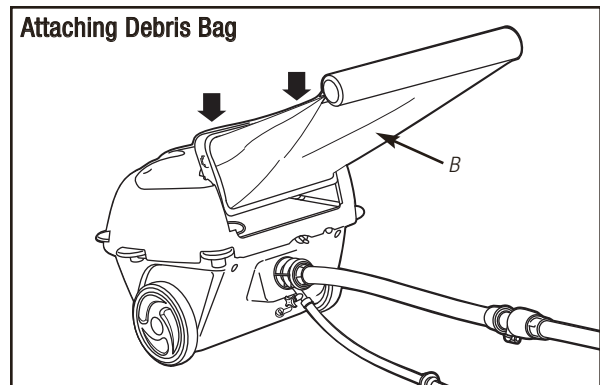

Figure 1

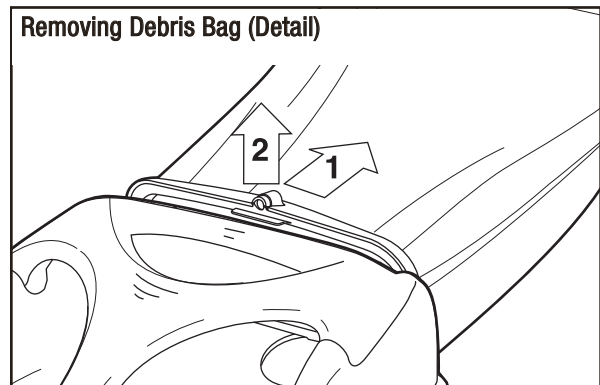

Figure 2

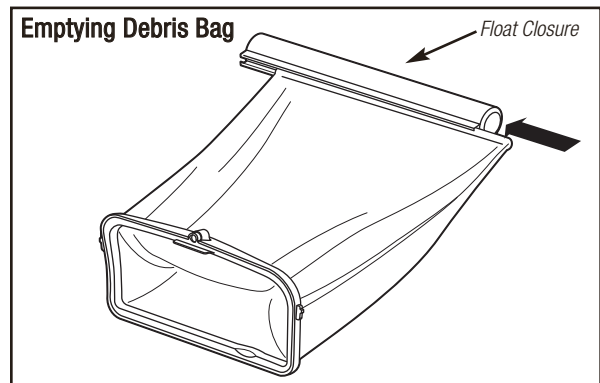

Figure 3

Correctly Operating Cleaner

Movement

When the Phantom cleaner is operating properly it will randomly travel around the bottom, sides and surface of the pool in "AUTO" mode. The cleaner will clean the bottom and walls 2/3 of its cycle and skim the surface 1/3 of the cycle. In "TOP" or "BOT" (Bottom) mode, the cleaner will stay in the Skimming or Bottom & Wall mode (respectively) until the switch is changed to a different mode.

Spin-Out

The cleaner will periodically stop and rotate clockwise in order to provide better pool coverage and to escape from corners and other obstacles. If the cleaner is momentarily stopped in a corner or at an obstacle, it will Spin-Out to free itself and continue moving randomly about the pool. The Spin-Out Cam determines the frequency of the Spin-Outs. The cleaner comes equipped with 3 Spin-Out Cams; every 75, 50 (factory installed) or 30 seconds (75 second and 30 second Cams are in the Accessory bag). To change Spin-Out Frequency see "Changing Spin-Out Cam".

Sweep Hose

The Sweep Hose should move in a slow, undulating (snake-like) motion. It moves debris out of tight corners so the cleaner can vacuum the debris at a more accessible spot in the pool. The Sweep Hose also stirs fine debris into suspension for removal by the pool's filtration system. **The Sweep Hose Rollers are wear parts.** When the rollers wear-down to the outer groove (Wear Line) replace the Wear Rollers (P/N AX5006A) a bag of extra Wear Rollers is included. If a hole forms in the Sweep Hose, it must be replaced with a genuine Hayward Phantom Sweep Hose (P/N AX5000RSHA).

Cleaning

When the cleaner is on the bottom or walls debris is vacuumed from below the cleaner and passed through the vacuum tube into the Debris Bag. When the cleaner is skimming the surface water jets push the debris into the Debris Bag where it is held until the user empties the Bag. The cleaner may not pick-up all debris on the first pass, but your pool should be clean in 3-hours or less (depending on pool size, shape and the amount of debris in the pool).

Observe the Phantom's operation at regular intervals and empty the bag as necessary. Only operate the Phantom for the time necessary to clean the pool. Excessive use is unnecessary and will cause premature cleaner wear.

Fine Debris

The Large Capacity Debris Bag, as with other pressure-side cleaners, does not hold very fine sand or other powder-like debris. Powder will be blown through the bag and into suspension so it can be filtered by the pool's filtration system.

Sand (Dense Debris)

If too much sand or heavy debris is collected in the Debris Bag, the bag will "droop" over the hose while on the bottom and may not be able to ascend to the surface. If you observe the bag drooping over the hose turn the booster pump off and empty the Debris Bag.

Pools with excessive amounts of sand should be manually vacuumed before installing the Phantom.

The Phantom is designed to operate with 1/2-cup of sand and the remainder of its bag filled with leaves, acorns, grasses, etc.

Pressure Hose

This hose has been designed to minimize the forming of loops and knotting. Most of the pressure hose should remain below the surface of the water the majority of the time. If the hose forms a loop the cleaner will eventually work it out. In the rare event the hose becomes knotted or tangled, it will limit the range of the cleaner. To get optimal coverage, remove knots or bad tangles if found.

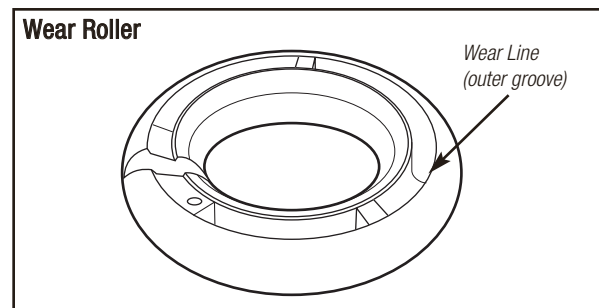
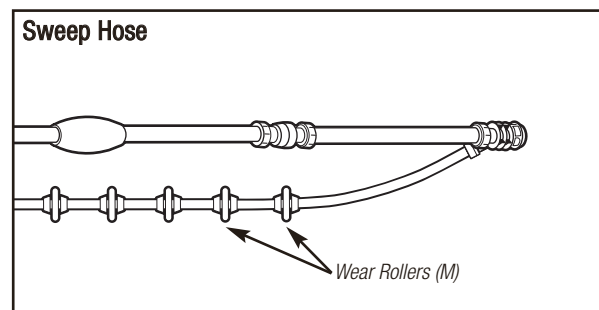
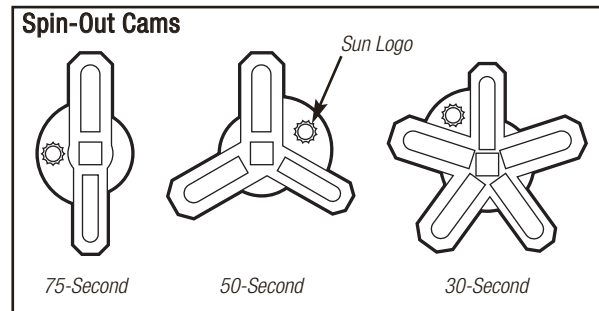

Phantom Turbo Cleaner Adjustments

Warning – Risk of Injury

Turn the Booster Pump and Filtration Pump OFF before making adjustments to the cleaner. Always make adjustments outside of the pool. Failure to do so may cause injury.

Changing Spin-Out Frequency

- In most pools it will not be necessary to change the Spin-Out frequency.
- The cleaner comes with a 3-prong Spin-Out cam installed, which makes the Phantom cleaner Spin-Out once every 50-seconds. This is appropriate for most pools.
- Pools that are small or have many sharp corners or other obstacles may benefit from more frequent Spin-Outs. For such pools, open the Cam Cap and replace the 3-prong cam with the 5-prong 30 second cam.
- Pools that are very large and/or have very few obstacles may benefit from less frequent Spin-Outs. For such pools, open the Cam Cap and replace the 3-prong cam with the 2-prong 75-second cam.
- The goal is to maximize cleaning time and minimize the amount of time spinning out.
- If the cleaner is spending too much time at an obstacle waiting for a Spin-Out, use a cam with more prongs for more frequent Spin-Outs.
- If the cleaner rarely needs to Spin-Out near an obstacle then a cam with fewer prongs and less frequent Spin-Outs will increase effective cleaning time.
- If the cleaner has a tendency to stay in the deep end (not cleaning the shallow end sufficiently), in pools with a particularly steep or long slopes between the deep and shallow ends, we recommend using a cam with fewer prongs, it will promote longer straight runs.

Changing Spin-Out Cam

1. Turn the Cam Cap counter clockwise to open.
2. Remove the Spin-Out Cam.
3. Place the desired Cam in place over the stem.
4. Place unused Cams in Accessory Bag and store in a safe place with the Owner's Guide.
5. Close the Cam Cap.

Adjusting Spin-Out Duration

Each Cam has a "Summer" side and a "Winter" side (see Sun & Snowflake logos on each Cam). The Summer side is usually preferred. If the pool water is cold (below 60 degrees F), the Pressure Hose becomes stiffer and may prevent the Cleaner from Spinning-Out enough to escape from obstacles. The "Winter" Cam side will provide longer Spin-Outs so the Cleaner operates better in cold water.

1. Turn the Cam Cap to open
 2. Remove the Cam, turn it over and replace the Cam so the desired (Sun or Snowflake) side is face-up.
- If the cleaner is making more than three attempts to escape from an obstacle, use the "Winter" side.
 - If the cleaner regularly spins-out more than three-quarters of a turn, use the "Summer" side.

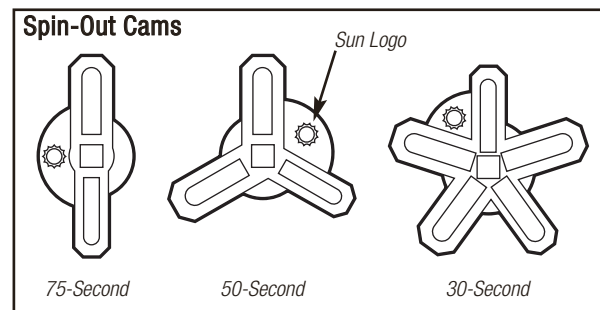
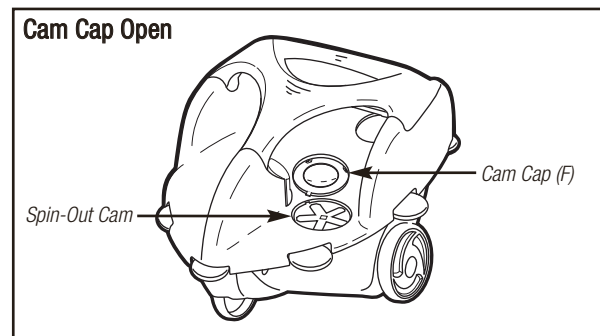
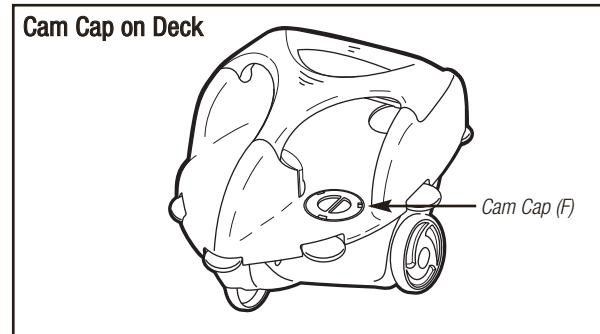

Changing Top and Bottom Operation

The Top/Bottom Switch (Part P, page 4) is set to "AUTO" at the factory. The Phantom Cleaner will vacuum the pool bottom and sides 2/3 of its cycle and skim the surface 1/3 of its cycle automatically.

The cleaner can be easily adjusted to concentrate on the areas of the pool with the most debris.

- To **ONLY** clean the bottom and sides of the pool, move the switch to the right "BOT".
- To **ONLY** skim the pool surface, move the switch to the left "TOP".

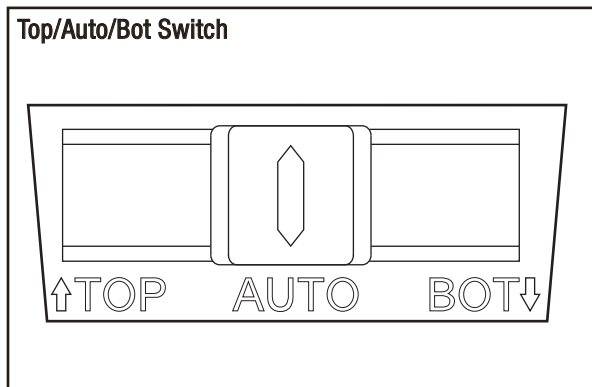

Adjusting Sweep Hose Power

- In most pools it will not be necessary to adjust the Sweep Hose power.
- Observe the Phantom cleaner operating in the pool. The Sweep Hose should move in a slow, undulating (snake-like) motion.
- **Sweep Hose Not Moving:** If the Sweep Hose does not move side-to-side and just drags behind the cleaner, check the Sweep Hose for holes. Check for debris behind the adjustment knob or in the jet-end of the Sweep Hose.
- **Sweep Hose Moves Slowly Or Not At All:** Turn the adjustment knob counter-clockwise to increase Sweep Hose power.
- **Sweep Hose Frequently Sprays Out Of The Pool:** Turn the adjustment knob clockwise to reduce Sweep Hose power.
Note: Do **NOT** turn the Sweep Hose completely off. This can cause the hose to tangle or knot.

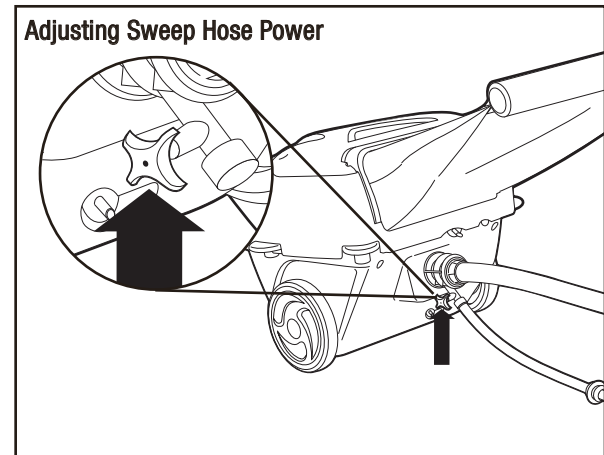

Maintenance

Removing the Phantom Turbo Cleaner From the Pool

⚠ Warning – Risk of Injury

The Booster Pump and Filtration Pump must be **OFF** when connecting or disconnecting cleaner or hose.

1. **Turn the Booster Pump and Filtration Pump OFF.** If you will not be replacing the cleaner before the next Booster Pump timer cycle, turn the Booster Pump Timer **OFF. Never** run the Booster Pump without the cleaner connected. **Failure to do so can cause serious injury.**

⚠ Caution - Risk of Equipment Damage

Never run the Booster Pump without the Cleaner connected. Doing so will damage the pump's motor and void the Booster Pump's warranty.

2. From the pool deck looking down push the Wall Quick Connect into the Universal Wall Fitting and turn it to the right (clockwise).
3. Pull the Wall Quick Connect out of the Universal Wall Fitting.
4. Grab the cleaner by the wing, and remove from the pool.
5. Disconnect the Cleaner Connector from the Phantom Cleaner.
6. Lay the Cleaner End of the Pressure Hose and the Sweep Hose flat and straight.

Important: Always store the Cleaner End of the Pressure Hose and the Sweep Hose straight, **not coiled**. The cleaner may not operate properly with these hoses bent.

Emptying the Debris Bag

- Empty the Debris Bag regularly. Do not continue to operate the Phantom when the bag is full.
 1. Hold Bag over trashcan or wherever debris is to be placed.
 2. Slide Float Closure off of bag.
 3. Hold open edges apart and shake debris from bag.
 4. Slide Float Closure onto bag.
- **Sand (dense debris): Always empty the Phantom Debris Bag when there is too much sand (or heavy debris).** If the Cleaner cannot climb to the surface in TOP or AUTO mode OR the Bag "droops" over the hose **turn the Booster Pump OFF and empty the Debris Bag.**
- When the bag is full of leaves or other debris, the debris may trap air in the bag while skimming the surface. If the trapped air prevents the cleaner from descending to the pool bottom, empty the Debris Bag.

DO NOT operate the Phantom if it runs on its side or upside-down.

Cleaning the In-Line Filters

1. The Hose In-Line filter (Part Q) is located by the Wall Quick Connect (Part K).
2. To remove the screen inside the In-Line Filter, unscrew the cap of the In-Line Filter and remove the screen.
3. Remove the debris from the screen and rinse. **Important:** If the screen frequently becomes plugged, the filtration system is not performing properly or there is another plumbing problem.
4. Place the open end of the screen into the outlet end of the In-Line Filter and screw the cap back on. **Important:** Make sure the O-Ring is in place and properly seated.

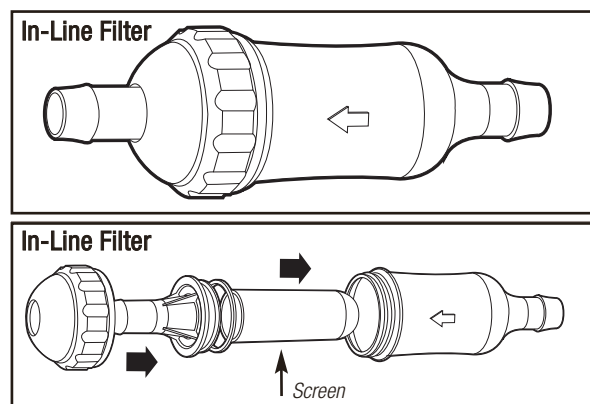

⚠ Caution - Risk of Equipment Damage

Never operate the cleaner without the screen in place. Operating the cleaner without the screen will damage the cleaner's internal mechanism.

5. Inlet Manifold filter screen stays in manifold inlet when hose is removed for storage.
6. If there is debris in the filter it can be removed for cleaning by grasping the bar and gently pulling while twisting.
7. Rinse to ensure that all debris and sand is removed from the inlet filter screen.
8. Before replacing the manifold, check that there is no debris visible inside of manifold inlet. If sand or debris can be seen, gently rinse out manifold using a water hose with inlet pointed down.

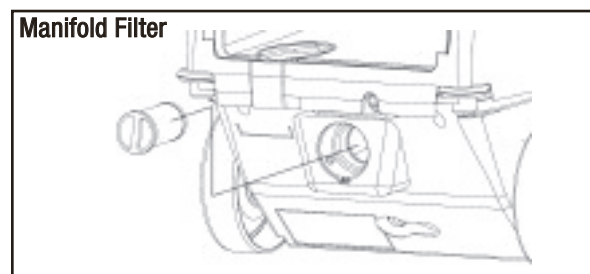

Storing the Phantom Turbo Cleaner

Sweep Hose

- Sweep Hose Wear Rollers will experience wear when operating in a plastered or concrete pool.
- When the Wear Rollers wear-down to the outer groove (Wear Line) replace the Wear Rollers (P/N AX5006A).
- Check the Sweep Hose for holes (Replace if necessary with P/N: AX5000RSHA).

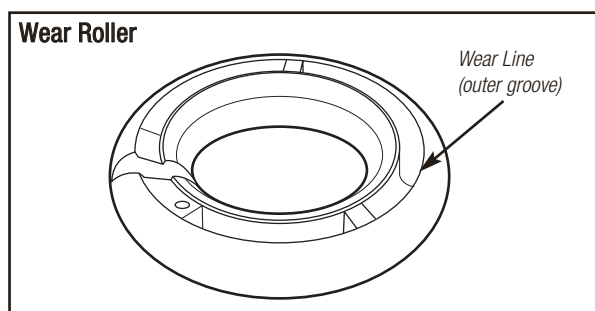

Some parts will wear with normal use. To ensure the high quality performance, insist on **Genuine Hayward replacement parts (using non-Hayward replacement parts will Void the Phantom Turbo Cleaner's Warranty)**. The following parts are user replaceable and subject to normal wear and tear.

1. **Sweep Hose:** If a hole forms in the Sweep Hose, it should be replaced. Unscrew the metal mender nut from the hose and pull the Sweep Hose (Sweep Hose Replacement Part Number: AX5000RSHA) off the Cleaner Connector. Attach a new Sweep Hose to the Cleaner Connector.
2. **Large Capacity Debris Bag with Float:** The Debris Bag should be replaced if it is torn (Replacement Part Number: AX6000BA).
3. **Swivels:** If a swivel ceases to turn easily or leaks while the cleaner is running, it should be replaced.

Storing the Phantom Cleaner

1. **Turn the Booster Pump OFF** and set the timer so the Booster Pump will not turn on while the Phantom cleaner is out of the pool (**Never** operate the Booster Pump without the cleaner connected).
2. Disconnect Wall Quick Connect from the Universal Wall Fitting. The Universal Wall Fitting may be left in place.
3. The cleaner is constructed of the finest materials available, however we recommend that when the Phantom cleaner is removed from the pool, it should be stored flat on its wheels in a shaded area to protect the unit from excessive exposure to sunlight.
4. Store the Sweep Hose and the Hose Cleaner End Assembly (Part S) straight and flat, **not coiled**. The Rigid Hose Pipe Sections may be folded on one another, so that the short hoses in-between are bent. If possible, store the hoses in the shade.

Winterizing the Cleaner

When closing your pool for the winter completely drain the water from the Phantom Cleaner (by slowly rotating it in all directions) and Hoses. Store the Phantom Cleaner indoors to prevent freezing of the inner mechanisms.

Periodic Freezing Conditions

If you are in an area subject to periodic freezing conditions, but pool equipment is kept in operation, it is very important that the filtration system and Phantom cleaner be in operation during times when hard freezing occurs (normally between 3 AM and 7AM). Running the Phantom cleaner at this time will ensure against damaging the Cleaner and may prevent freezing the pool water.

Troubleshooting

For Technical Assistance Call:

1-800-429-9273

Problem	Cause	Solution
Slow or no Forward Movement	Low or No Water Pressure	Check Filtration and Booster Pumps, Valves, Cleaner Connections. Check Cleaner Pressure and In-Line Filter. (Page 9 and Page 14)
No Spin-Out	Cam Not Properly Installed	Open Cam Cap. Check that Cam Properly Installed. Close Cam Door. (Page 12)
	Gearbox not Rotating	With the Cleaner Running, Open Cam Cap and Confirm that Cam is Rotating. If not, have your Gearbox (AX6000GA) Replaced
Cleaner Stuck in Top or Bottom Mode	Mode Adjustment Tab not in Top / Auto / Bot Switch	Put Switch in Desired Mode (Top, Auto or Bottom)
Cleaner Does Not Reach Farthest Point in Pool	Hose Too Short	Check Hose Length (Page 7)
Hose Frequently Tangles	Float not Properly Placed	Check Float is Centered on the Two-Foot Hose Connected to the Pipe Closest to the Cleaner
	Hose Too Long	Check Hose Length (Page 7)
	Spin-Out Too Long and/or Too Frequent	Check Summer/Winter Position of Cam, (Page 12) Use Spin-Out Cam with Fewer Prongs. (Page 12)
	Sweep Hose Not Moving	Check Sweep Hose for Holes or Clogs. Increase Sweep Hose Power. (Page 13)
Cleaner Head Cannot Escape from Some Corners	Spin-Out Too Short	Change Cam to Winter Position. (Page 12)
Cleaner Head Rotates More Than 3/4 Turn During Spin-Out	Spin-Out Too Long	Change Cam to Summer Position. (Page 12)
Sweep Hose Sprays Out Of Pool	Sweep Hose Power Too Strong	Reduce Sweep Hose Power (Page 13)
Little Or No Sweep Hose Movement	Sweep Hose Power Too Weak	Increase Sweep Hose Power (Page 13)
	Hole In Sweep Hose	Replace Sweep Hose (P/N AX5000RSHA)
	Debris Clogging Sweep Hose	Disconnect Sweep Hose and Flush Out
Phantom Running On Side or Upside Down	Heavy Debris	Empty Bag
	Pressure Too High	Check Operating Pressure (Page 9)
Cleaner Cannot Climb to the Surface in TOP or AUTO Mode	Pressure Too High or Too Low	Check Operating Pressure (Page 9)
	Too Much Heavy Debris in Bag	Empty Bag
Cleaner runs in Small Circles	Hose on Hose Cleaner End Assembly Bent	Layout in Sun Until Straight

Booster Pump Typical Installation

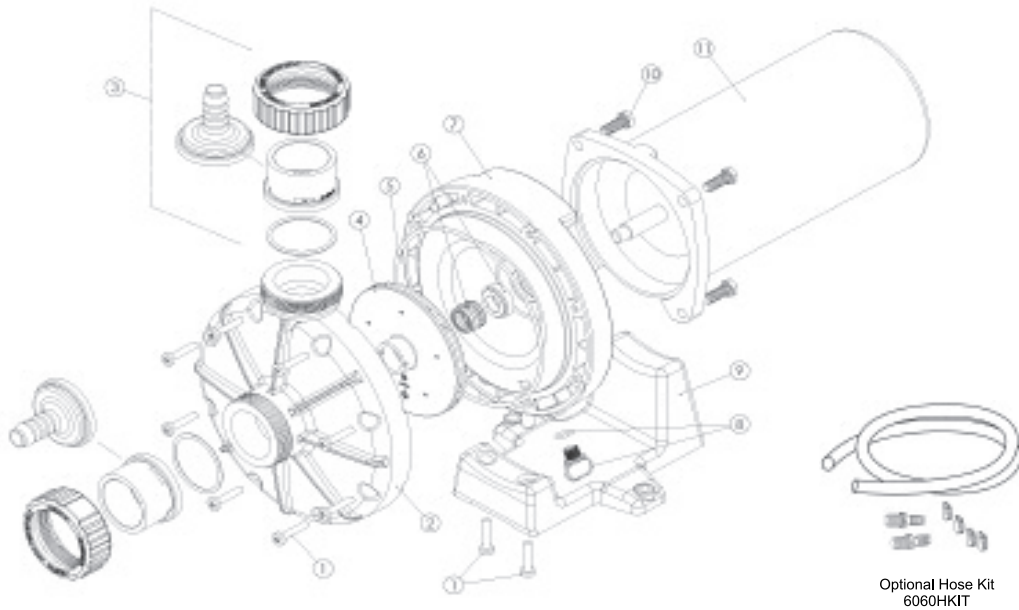
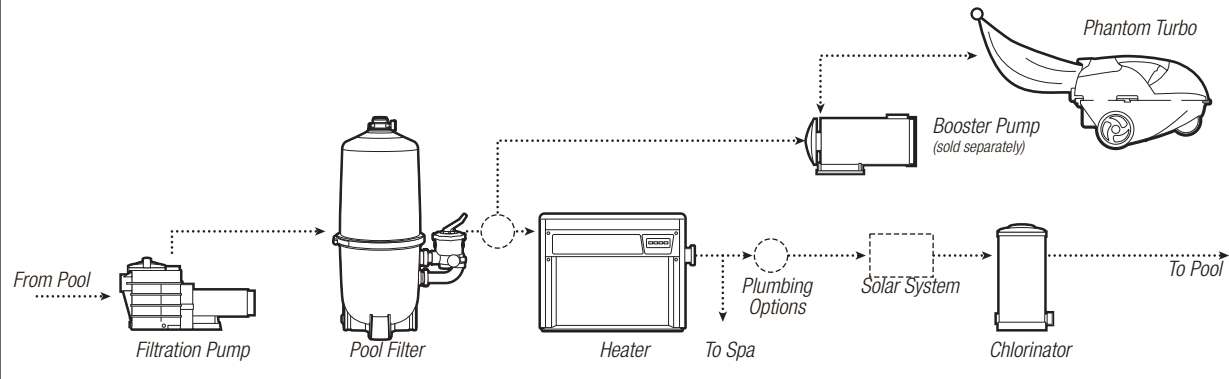

Ref. No.	Part No.	Description
1	AX6060Z1	Screw, 1/4" Type b x 1-1/4" (Set of 10)
2	AX6060A	Pump Volute
3	AX6060UNPAK	Union Connector Kit (incl. 2 ea. Union Hose Connector, Union Pipe Connector, Union Nut, and Union O-Ring)
4	AX6060C	Impeller Assembly
5	AX6060S	Seal Plate O-Ring
6	SPX2700SA	Shaft Seal Assembly
7	AX6060E	Seal Plate Assembly (incl. Drain Plug w.O-Ring)
8	SPX4000FG	Drain Plug w/O-Ring
9	AX6060G	Motor Support
10	SPX3200Z5	Motor Belt
11	SPX2707Z1B	Motor, 3/4 HP, Square Flange
	6060HKIT	Hose Kit (incl. Hose, 2 Hose Fittings, and 4 Hose Clamps)

Phantom Turbo Parts Diagram

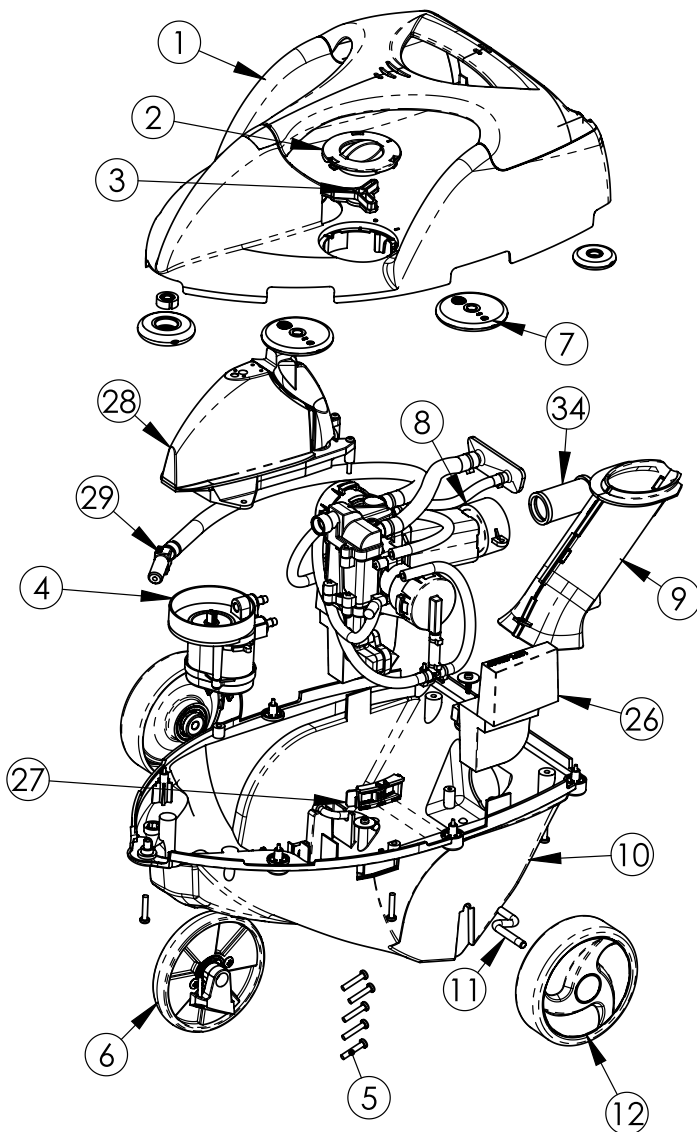
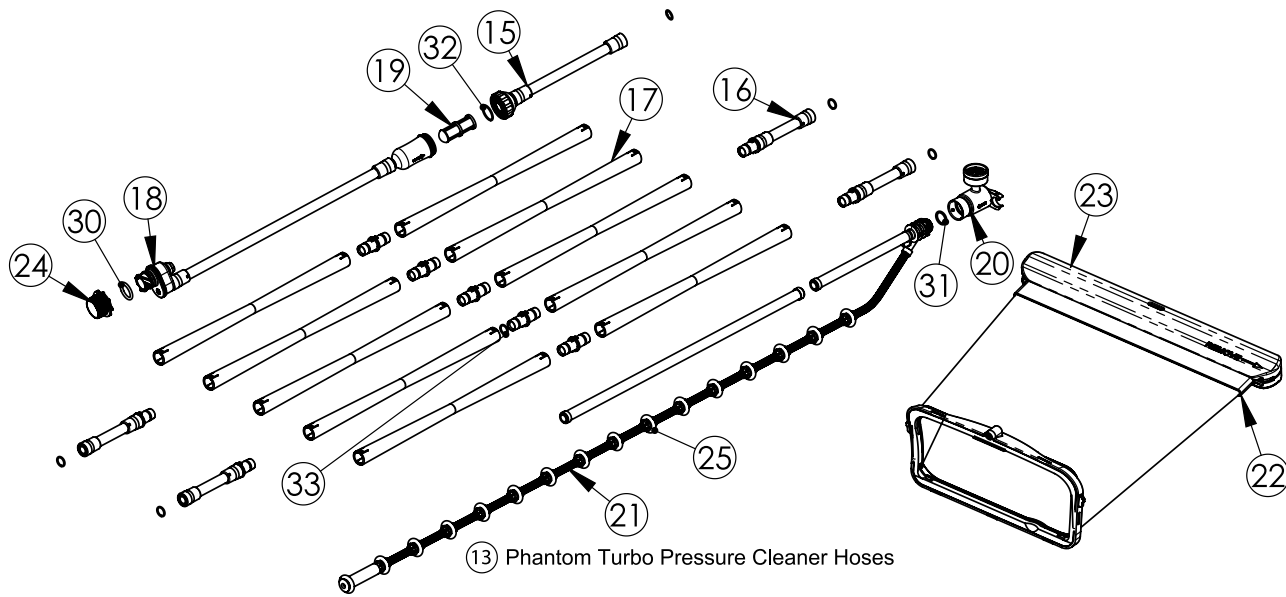

Ref. No.	Part No.	Description
1	AX6000TA	Deck (with Wing & Cam Cap)
2	AX6001F	Cam Cap
3	AX5003M	Cams (3-pack)
4	AX6000GA	Gearbox (with Cams, Hoses & Ties)
5	AX5010D4	Screws (5-pack)
6	AX6009BF	Front Wheel (with Retainer & Bearing)
7	AX6000D	Soft Rollers (7-pack with Bearing)
*8	AX6000MA3	Turbo Manifold Assembly (with Hoses & Ties)
9	AX5000B	Vac Tube
10	AX5000A2	Bottom Housing
*11	AX5009E1	Rear Axle Split (2 Pack)
12	AX6009B	Rear Wheels (with Bearings, Axle, Nuts & Hubcaps)
13	AX6000HA	Rigid Pressure Hose (complete)
14	AX6000HCA	Pressure Hose Cleaner End Assembly (Without Sweep Hose)
15	AX6000HWA2	Pressure Hose and Top of In-Line Filter Assembly
16	AX6000HFA	Hose Swivel Assembly
17	AX6000HE	Rigid Hose Pipe Section (2 Rigid Pipes & 1 Coupling)
18	AX6000HWA1	Wall Quick Connect, Hose, Bottom In-Line Filter Assembly
19	AX6009S	In-Line Filter Screen
20	AX6000PTA	Set-up Pressure Gauge
21	AX5000RSHA	Sweep Hose (with Rollers & Mender Nut)
22	AX6000BA	Large Capacity Debris Bag (with Float)
23	AX6000FC	Float Closure
24	AX5004L1	Universal Wall Fitting
25	AX5006A	Wear Rollers (10-pack)
26	AX5500EF	Floats (Left & Right)
27	AX6000SWA	Top / Auto / Bot Switch
*28	AX6000TNKA	Nose Jet Tank
29	AX6008M	Front Spin-Out Jet (with Hose & Tie)
30	AX5010G10	Wall Quick Connect O-Ring
31	AX5010G18	Cleaner Connector O-Ring
32	AX5010G19	In-Line Filter O-Ring
33	AX5010G20	Pipe Connector O-Ring (3-pack)
*34	AX6004R1	Inlet Filter Screen

*Denotes New Part Numbers.

Important!

Retain Your Bill of Sale For Proof of Warranty Eligibility

To the Original Retail Consumer / Purchaser (the "PURCHASER") of the Hayward Phantom Turbo Automatic Pool Cleaner (the "CLEANER").

Hayward Pool Products, Inc. ("HAYWARD") warrants the parts for One (1) year from the date of original purchase (excluding the bag and sweep hose which are normal replacement parts).

The Hayward Booster Pump is excluded in this warranty and carries its own separate warranty.

SHOULD THE CLEANER FAIL TO BE IN GOOD WORKING ORDER IN ACCORDANCE WITH THE ABOVE SCHEDULE, HAYWARD WILL AT ITS OPTION REPAIR OR REPLACE THE CLEANER OR ANY DEFECTIVE PARTS AT NO ADDITIONAL CHARGE EXCEPT AS SET FORTH BELOW. REPAIR PARTS AND REPLACEMENT PRODUCTS WILL BE FURNISHED ON AN EXCHANGE BASIS AND WILL BE NEW OR FUNCTIONALLY EQUIVALENT. ALL PARTS REMOVED AS A RESULT OF REPLACEMENT SHALL BECOME THE PROPERTY OF HAYWARD. LIABILITY OF HAYWARD AND THE SOLE REMEDY OF THE PURCHASER WHETHER IN CONTRACT UNDER ANY WARRANTY, IN TORT (INCLUDING NEGLIGENCE), IN STRICT LIABILITY OR OTHERWISE, SHALL BE LIMITED TO THE REPAIR OR REPLACEMENT OF DEFECTIVE PARTS ONLY AND SHALL IN NO EVENT EXCEED THE RETURN OF THE AMOUNT OF THE PURCHASE PRICE PAID BY THE PURCHASER.

THIS LIMITED WARRANTY IS SUBJECT TO THE FOLLOWING TERMS AND CONDITIONS:

1. This Limited Warranty shall not apply to damage caused by failure to perform normal maintenance on the CLEANER (e.g. monitoring pressure/flow and replacing a worn bag and sweep hose).
2. This Limited Warranty shall be void if the CLEANER is modified in any respect, including, but not limited to the use of any parts other than Genuine Hayward Parts.
3. This Limited Warranty shall not apply to any injury, loss, damage, defect or malfunction of the CLEANER or failure of the CLEANER to function resulting from any failure to operate or maintain the CLEANER in accordance with the directions contained in the Owner's Guide provided by HAYWARD or any injury, loss, damage, defect, malfunction or failure to function resulting from any misuse, unreasonable use, tampering, abuse, accident, act of God, alterations in the CLEANER by anyone other than HAYWARD including but not limited to such damages or injuries to parts resulting from running pump dry (e.g. interruption in or inadequate supply of water to the Booster Pump, or obstruction in lines, or otherwise); or damage, defects, or malfunctions resulting from defects in, failure or malfunction of, or negligence, abuse, or misuse with respect to equipment other than the CLEANER.
4. This Limited Warranty shall not apply to the malfunction of, damage to, materials failure in, or changes in the appearance of the CLEANER resulting from exposure to sunlight or chemicals or chemical reactions to substances with which any part of the CLEANER may come in contact or parts if worn, do not affect performance of the CLEANER.
5. This Limited Warranty does not apply to cleaners used for commercial purposes.
6. The CLEANER is designed to function in a properly designed, constructed and maintained pool. The Limited Warranty does not apply in the circumstances where the pool's design, construction or maintenance is defective, substandard or inappropriate for the CLEANER'S operation.
7. Deterioration, discoloration or brittleness of pool plaster and vinyl liners can be caused over time separately by, or in combination with, algae and an imbalance in pool water chemistry, improper installation, and other factors.

Limited Warranty

Limited Warranty

HAYWARD hereby disclaims any and all claims, and PURCHASER releases HAYWARD from any and all claims for damages to any pool plaster or vinyl liner in PURCHASER'S pool by reason of the use and/or operation of the CLEANER

8. This Limited Warranty is valid and enforceable only on CLEANERS assembled, manufactured, or purchased and installed in the United States of America and Canada.
9. This Limited Warranty shall apply to PURCHASER as original purchaser of the CLEANER from an authorized HAYWARD dealer and shall not apply to any subsequent purchaser, assignee or other recipient of the CLEANER from the PURCHASER.
10. **This Limited Warranty does not apply unless the accompanying Registration Card is signed, completed and returned within fourteen (14) days from the date of purchase or an equivalent warranty form is complete online at www.haywardnet.com/warranty.** Hayward reserves the right to dispose of any Registration Card once it is received. PURCHASER must retain written proof of purchase.
11. The foregoing Limited Warranty gives the PURCHASER specific legal rights, which may vary from state to state, and accordingly, some of the listed conditions, and exclusions may not apply to PURCHASERS living in certain states.
12. Neither party will be liable to the other for any failure or delay in performance due in whole or in part to any cause beyond such party's reasonable control, including due to the elements, acts of God, acts of the other party, acts of civil or military authority, war, riots, or concerted labor action.
13. The PURCHASER has no right to sell, transfer or assign interest it has in this agreement without the prior written consent of HAYWARD. HAYWARD may, without notice, assign its interest in this agreement or any payment or other sum due hereunder without notice to or prior consent of the PURCHASER. If Hayward makes any such assignment, the assignee will have all of HAYWARD's rights, obligations, powers, privileges and remedies. Modification of this Agreement may only be made in writing signed by an authorized agent of HAYWARD.

Should a defect in workmanship and /or materials in the CLEANER become evident during the term of the Limited Warranty, PURCHASER must ship the item freight prepaid to any authorized Factory Service Center as soon as possible after the discovery of the defect, together with a copy of the Bill of Sale including date of purchase and serial number of the item claimed to be defective, the name and address of the PURCHASER and a brief description of the problems/defects encountered. Call (800) 227-1477 for the name and address of the nearest

Factory Service Center (outside the continental U.S. call (909) 594-1600).

HAYWARD will at its option, repair or replace the defective CLEANER parts covered by this Limited Warranty at its own cost and expense and return the same to the PURCHASER freight prepaid. HAYWARD is not responsible for any cost and expense of handling, packing, shipping or transporting the CLEANER or any parts to or from the Factory Service Center, unless expressly provided to the contrary by state law. No dealer, distributor or other similar person has any authority to make any warranties or representations concerning HAYWARD beyond the express terms contained herein. HAYWARD assumes no responsibility for any warranties beyond the express terms contained in this Limited Warranty. This Limited Warranty is in lieu of any other warranties expressed or implied, and is valid and enforceable only in the United States of America and Canada. The PURCHASER must provide written proof of the original date of purchase of the CLEANER in form reasonably acceptable to HAYWARD.

The exclusive forum for any dispute between the PURCHASER and HAYWARD will be binding arbitration, conducted in Union County, New Jersey under the rules of the American Arbitration Association, and the prevailing party will be entitled to an award of attorney's fees and costs.

THE FOREGOING WARRANTY AND REMEDIES ARE EXCLUSIVE AND ARE MADE EXPRESSLY IN LIEU OF ALL OTHER WARRANTIES, EXPRESSED OR IMPLIED, WHETHER IN FACT OR BY OPERATION OF LAW, STATUTORY OR OTHERWISE, INCLUDING WARRANTIES OF MERCHANTABILITY AND FITNESS FOR USE OR A PARTICULAR PURPOSE. HAYWARD NEITHER ASSUMES NOR AUTHORIZES ANY OTHER PERSON TO ASSUME FOR IT ANY OTHER LIABILITY IN CONNECTION WITH THE SALE, INSTALLATION OR USE OF THE CLEANER AND HAYWARD MAKES NO WARRANTY WHATSOEVER FOR EQUIPMENT NOT SUPPLIED BY HAYWARD. THE FOREGOING WARRANTY DOES NOT COVER DAMAGE TO THE CLEANER RESULTING FROM ACCIDENT, MISUSE, ABUSE, OR NON-HAYWARD MODIFICATIONS OF THE CLEANER. HAYWARD SHALL NOT BE LIABLE FOR DAMAGES DUE TO DELAYS IN DELIVERY OR USE. IN NO EVENT WILL HAYWARD BE LIABLE TO THE PURCHASER FOR ANY DAMAGES INCLUDING, BUT NOT LIMITED TO, ANY DIRECT, SPECIAL, INCIDENTAL OR CONSEQUENTIAL DAMAGES ARISING OUT OF OR RELATING TO THE SALE, INSTALLATION, OR USE OF OR INABILITY TO USE THE CLEANER, PURCHASER'S SWIMMING POOL OR FOR ANY OTHER CLAIM BY ANY OTHER PARTY.

HAYWARD™
PHANTOM **M**
TURBO™

Hayward Pool Products, Inc.

2875 Pomona Blvd.
Pomona, CA 91768

Phone: (800) 227-1477

www.haywardnet.com